



**INSTALLATION AND INSTRUCTIONS MANUAL
TP-TM-TW RECTIFIERS**

0 – INTRODUCTION 7

 0.1 – PURPOSE OF THE MANUAL, INSTRUCTIONS FOR USE AND MAINTENANCE..... 7

 0.2 – HOW TO READ THE INSTRUCTION MANUAL 7

 0.3 – MAINTENANCE OF INSTRUCTION MANUAL 8

 0.4 – METHODOLOGY FOR UPDATING THE INSTRUCTION MANUAL 8

 0.5 – ADDRESSES 8

 0.6 – GLOSSARY AND PICTOGRAMS 9

1 – GENERAL INFORMATION 13

 1.1 – IDENTIFICATION DETAILS OF MANUFACTURER 13

 1.2 – IDENTIFICATION DATA AND NUMBER OF THE MACHINE 13

 1.3 – DECLARATIONS 13

 1.4 – SAFETY REGULATIONS 13

 1.5 – INFORMATION ON TECHNICAL ASSISTANCE 13

 1.6 – PREPARATIONS BY THE CUSTOMER 13

2 – DESCRIPTION OF THE RECTIFIER 14

 2.1 – DESCRIPTION OF THE RECTIFIER 14

 2.2 – FIELD OF USE 14

 2.3 – CONSTRUCTIO CHARACTERISTICS MODULAR RECTIFIERS 14

 2.4 – CONSTRUCTIO CHARACTERISTICS MODULAR RECTIFIERS WITH POLARITY REVERSE 14

 2.5 – ELECTRICAL CHARACTERISTICS 14

 2.6 – CHARACTERISTICS OF CONTROL AND COMMUNICATIONS 14

 2.7 – DIMENSIONS AND WEIGHTS 15

 2.8 – ENVIROMENTAL CONDITIONS 15

 2.9 – LIGHTING 15

 2.10 – VIBRATIONS 15

 2.11 – NOISE EMISSION 15

 2.12 – STANDARD SUPPLY 15

3 – SAFETY16

3.1 – GENERAL SAFETY ADVICE 16

3.2 – ENVISAGED USE 18

3.3 – CONTRAINDICATIONS OF USE 18

3.4 – HAZARDOUS AREA 18

3.5 – SAFETY DEVICES 19

3.6 – SIGNS 19

3.7 – RESIDUALS RISKS 19

4 – INSTALLATION20

4.1 – TRANSPORTATION AND HANDLING 20

4.2 – STORAGE 21

4.3 – PREPARATIONS 21

4.4 – POSITIONING 22

4.5 – PREPARATIONS 23

4.6 –MULTI-TOWER RECTIFIERS – CONNECTIONS 24

4.7 – PRELIMINARY CHECS 25

4.8 – NO LOAD TESTS 25

4.9 – LOAD TESTS 25

5 – USE OF MACHINE26

5.1 – ELECTRICAL CONNECTIONS, INSTRUMENTATION AND SIGNALS 26

5.2 – MACHINE SETTINGS 26

5.3 - RUNNING AND STOPPAGE 27

5.4 - VOLTMETER AND AMMETER 27

5.5 - POLARITY REVERSAL (ONLY FOR MACHINES THAT PROVIDE IT) 28

5.6 - STABILISATION SELECTION 28

5.7 – TIMER 29

5.8 – PROCESS TIME 29

5.9 - RAMP 30

5.10 - PULSED MODE FUNCTION (ONLY FOR MACHINES THAT PROVIDE IT) 30

5.11 - TEMPERATURE MODULES 32

5.12 – CURRENTS DELIVERED MODULES 32

5.13 - PARTIAL AND TOTAL AMPERE MINUTES 33

5.14 - PARTIAL AND TOTAL AMPERE MINUTES RESET 33

5.15 - DOSER PUMPS (ONLY FOR MACHINES THAT PROVIDE IT) 33

5.16 – ADDRESS 34

5.17 - FULL SCALE DISPLAY 35

5.18 - LOCAL/AUTO FUNCTIONING SET (IF DISPLAYED) 35

5.19 - RECTIFIER SERIAL NUMBER 35

5.20 - WATER SOLENOID VALVE CONTROL / WATER RECTIFIERS 36

5.21 - LOW LEVEL VOLTAGE / CURRENT ALARM (IF ACTIVATED) 36

5.22 – PASSWORD ENTER EXTRA FUCTIONS 37

5.23 – EXTRA FUNCTIONS 37

5.24 - ALARMS MANAGEMENT 45

6 - MAINTENANCE 47

6.1 – SPECIAL PREACUTIONS 47

6.2 – MAINTENANCE 47

6.3 – ALARMS 50

7 – SPARE PARTS AND ACCESSORIES 51

7.1 – ASSISTANCE 51

7.2 – SPARE PARTS 51

8 – FURTHER INSTRUCTION 52

8.1 – WASTE DISPOSAL 52

8.2 – PUTTING OUT OF ACTION AND DISMANTLING 52

8.3 – SAFE WORK PRACTICES 52

9 – ANNEXED 53

9.1 - TP SERIES RECTIFIERS DIMENSIONS 53

9.2 - TP SERIES ELECTRICAL FEATURES 54

9.3 - FULL VIEW OF TP SERIES..... 55

9.4 - POWER SUPPLY TP SERIES..... 56

9.5 - TM SERIES DIMENSIONS..... 57

9.6 - TM SERIES ELECTRICAL FEATURES..... 58

9.7 - FULL VIEW OF TM SERIES 59

9.8 - POWER SUPPLY OF TM SERIES 60

9.10- TY SERIES RECTIFIERS DIMENSIONS 61

9.11 - TY SERIES ELECTRICAL FEATURES 62

9.12 - FULL VIEW OF TY SERIES..... 63

9.13 - POWER SUPPLY TY SERIES 63

9.14 - TW SERIES DIMENSIONS..... 64

9.15 - TW SERIES ELECTRICAL FEATURES..... 65

9.16 - FULL VIEW OF TW SERIES RECTIFIERS 67

9.17 - POWER SUPPLY OF TW SERIES 68

9.18 - DE100 REMOTED..... 69

9.19 - DE20X REMOTED..... 70

9.20 - DOSING PUMPS CONNECTION 71

9.21 - ANALOGICAL CONNECTION 72

9.22 - MODBUS-RTU..... 73

9.23 - PROFIBUS-DP..... 74

9.24 – PROFINET – MODBUS-TCP..... 74

9.25 -- CONFORMITY DECLARATION **CE**..... 75

0 – INTRODUCTION

0.1 – PURPOSE OF THE MANUAL, INSTRUCTIONS FOR USE AND MAINTENANCE

This instruction manual is an integral part of the machine and is designed to provide all information necessary for:

- The correct familiarisation of operators with issues of safety;
- The safe handling of the machine, packaged and unpacked;
- The correct installation of the machine;
- In-depth knowledge of its operation and its limits;
- Its proper and safe use;
- Performance of maintenance activities, correctly and safely;
- Dismantling the machine in a safe manner and in compliance with existing laws to protect the health of workers and the environment.



**The heads of departments, where this machine will be installed, have an obligation, in accordance with regulations, to read the contents of this document and read it to tenants and maintenance workers, for the parts that they compete.
The time spent for the purpose will be largely compensated by the correct operation of the machine and by its use in conditions of safety.**

This document indicates that in plants, where the machine was designed to be used, the regulations currently in force relating to safety are complied with as well as standards of hygiene at work.

The instructions, drawings and documentation in this manual are of a reserved technical nature, strictly the manufacturer's property and may not be reproduced in any way, either in whole or in part

0.2 – HOW TO READ THE INSTRUCTION MANUAL

This manual has been divided into independent chapters, each of which addresses to a specific operator figure (INSTALLER, DRIVER and MAINTENANCE) who have the skills needed to operate the machinery safely. The sequence of chapters responds to the temporal logic of the life of the machine. To facilitate the ready understanding of the text, terms, abbreviations and pictograms have been used, the meaning of which is explained on this chapter.

The instruction manual consists of a cover, an index and a series of chapters (sections).

The specifications of the machine and the model (and any register numbers), a review of the manual instructions and, finally, a photo / drawing of the type of machine described are listed on the first page in order to assist the reader in identifying the machine and its relevant manual.

UNIT OF MEASUREMENT

The units of measurement used are those established by the System International (SI).

0.3 – MAINTENANCE OF INSTRUCTION MANUAL

The instruction handbook should be stored with care and must accompany the machine at all stages of property that the same may have in its life.

The manual must be handled with care, with clean hands and not placing it on dirty surfaces. It must not be removed, torn or arbitrarily modified.

The manual should be stored in an environment protected from moisture and heat and in the vicinity of the machine to which it relates.

The manufacturer, at the request of the user, may provide additional copies of the instruction manual of the machine

0.4 – METHODOLOGY FOR UPDATING THE INSTRUCTION MANUAL

The manufacturer reserves the right to amend the plan and make improvements to the machine without notifying this to the customer and without updating the manual already supplied to the user. However, if changes are made to the machine installed at the premises of the customer, agreed with the manufacturer and which comprise the change of one or more chapters of the instruction handbook, it will be the manufacturer's responsibility to send to the holders of the instruction manual involved the chapters affected by the change, along with the new comprehensive blueprint of the same.

It is the responsibility of the user, following the guidelines accompanying the updated documentation, to replace in all copies owned the old with the new chapters, the front page and index with those with the new revised level. The manufacturer is responsible for the descriptions reported in Italian; any translations may not be fully verified, and, as such, if an inconsistency is detected, attention must be paid to the Italian language version and eventually to contact our sales office which will make any amendments considered appropriate

0.5 – ADDRESSES

The manual in question is addressed to the installer, the operator and those members of staff qualified to carry out maintenance of the machine.

It is hereby specified that "**OPERATOR**" means the member of staff responsible for operating, adjusting, cleaning and performing routine maintenance of the machine.

By "**MEMBERS OF STAFF QUALIFIED**" or "**OPERATOR QUALIFIED**" it shall be understood those persons who have followed courses of specialization, training, etc. and have experience relating to installation, putting into operation and maintenance, repair and transportation of the machine.

By "**EXPOSED PERSON**" it is understood any person inside or near a machine where the presence constitutes a risk to the security, health or the personal safety of such person.

The machine is intended for industrial use and therefore professional and not generalised and as such, its use should be entrusted to qualified persons, particularly those that:

- Have been adequately trained on the use and maintenance of the machine;
- Those who are considered suitable by the employer to undertake such work;
- Be able to understand and interpret the manual and the safety requirements;
- Be aware of the emergency procedures and their implementation;
- Have the ability to operate the specific type of equipment;
- Be familiar with the specific regulations applicable;
- Have understood the operating procedures established by the manufacturer of the machine.

0.6 – GLOSSARY AND PICTOGRAMS

In this paragraph are listed the terms uncommon or otherwise with a different meaning from the common. Below in the paragraph the abbreviations used are explained, and the meaning of the pictograms used to indicate the operator qualification and the state of the machine, their use allows to provide quickly and unambiguously the information necessary for the correct use of the machine in safe conditions .

GLOSSARY

HAZARDOUS ZONE: Area within and / or near the machine where the presence of an exposed person constitutes a risk to the health and safety of the same person (Attachment I, 1.1.1 Directive 98/37/EC) ; **EXPOSED PERSON:** Any person who is wholly or partially in an area of danger (Attachment I, 1.1.1 Directive 98/37/EC);

OPERATOR: Person in charge of installing, operating, adjusting, maintaining, cleaning, repairing or transporting the machine (Attachment I, 1.1.1 Directive 98/37/EC),

MAN-MACHINE INTERACTION: Any situation in which an operator is found to interact with the machine in any of the operational steps at any time during the life of the same;

QUALIFICATION OF THE OPERATOR: Minimum level of competence that an operator must have to perform the operation described;

NUMBER OF OPERATORS: Number of operators appropriate to perform optimally the operation described above and resulting from careful analysis carried out by the manufacturer, such that a user with a different number of staff may be prevented from obtaining the desired result or endanger the safety of personnel involved;

STATE OF THE MACHINE, means:

- operation mode: automatic gear, with control of action maintained (jog), stop, etc.
- the condition of safety features on the machine: protectors included, protectors excluded, emergency stop button, type of insulation of energy sources, etc.

RESIDUAL RISK: Risk that can't be eliminated or sufficiently reduced by design, against which the forms of protection are not (or are not totally) effective; within the manual is provided information of such existence along with instructions and warnings to enable such risks to be overcome (see, respectively, 5.5 and 5.5.1 of the European standards EN 292/1 and EN 292/2);

SAFETY COMPONENTS: This means a component used to ensure a safety function, the failure or malfunction of which jeopardises the safety and/or health of persons exposed (e.g. lifting equipment; fixed, mobile, adjustable protectors, etc., electrical, electronic, optical pneumatic, hydraulic devices that power, or interlock, a protector, etc.).







PICTOGRAMS



The descriptions preceded by this symbol contain very important information / prescriptions, particularly as it regards the safety. The missed respect can involve:







- dangers for the safety of the operators;
- loss of the contractual guarantee;
- - declination of the responsibilities of the manufacturer

PICTOGRAM RELATING TO THE STATUS OF THE OPERATOR

SYMBOL	DESCRIPTION
	Generic labourer: operator lacking specific skills, able to perform only simple tasks on the orders of skilled technicians.
	Lifting and handling workers: operator qualified for use of means of lifting and moving of materials and Machines (scrupulously following the manufacturer's instructions) in accordance with the laws currently in force in the country of the user of the machine.
	Machine operator level 1: operator lacks specific skills, able to perform only simple tasks or the operation of the machine through the use of buttons arranged on a control box, loading and unloading of materials used during production, with protections installed and active; is not qualified for the use of the machine operating by jogging inching operation (JOG).
	Machine operator level 2: personnel able perform the duties of 1st level machine operator and, moreover, able to operate the machine with jogging inching operation (JOG), to typically carry out simple functions of the starting of production or its recovery after stopping and adjustments
	Maintenance technician: qualified technician, able to operate the machine under normal conditions, to make it work with jogging inching operation (JOG) with protection disabled, to examine the mechanical parts to make adjustments, carry out maintenance and repairs needed. Typically not entitled to work on electrical systems in the presence of voltage
	Electrical maintenance technician: qualified technician able to operate the machine under normal conditions, to make it work with jogging inching operation (JOG) with protection disabled, including all interventions relating to electrical adjustment, maintenance and repairs. Can operate in the presence of voltage within junction boxes and cabinets.
	Constructor technician: qualified technician made available by the manufacturer for the execution of complex operations in particular situations or, in any case, as agreed with the user. The skills are, depending on the cases, mechanical and/or electrical and/or electronic and/or software.

PICTOGRAM RELATING TO THE STATE OF THE MACHINE

- The pictograms contained in a square/rectangle provide INFORMATION

SYMBOL	STATE OF THE MACHINE
	Machine off: with electrical and pneumatic power cut off
	Machine on: with electrical and pneumatic power connected and able to be safely stopped using open mobile protectors (specifying which); JOG not enabled; fixed protectors closed
	Machine on: with electrical and pneumatic power connected and able to be safely stopped using mushroom push button in a depressed position or other system of command for such purpose, located near the area of operation (specifying which button or system to be used).
	Machine in motion: with automatic operation, mobile protectors sealed with the relevant interlocking devices activated and protectors held closed.
	Machine in motion, operating with jogging inching operation (JOG), protectors closed mobile devices with its interlocking activated and fixed protectors closed.
	Machine in motion, with jogging inching operation (JOG), one or more mobile protectors, which can be excluded, open (specifying which) together with the relevant interlocking device disabled, any remaining mobile protectors sealed with the interlocking devices activated and fixed protectors fixed
	Machine on: firm and ready for activation (conditions of stand-by) with functional consensus activation (e.g. presence of product), mobile protectors sealed with safety devices included and fixed protectors closed.

PICTOGRAMS RELATING TO SAFETY

- The symbols contained in a triangle indicate **DANGER**.
- The symbols contained in a circle impose an **OBLIGATION / PROHIBITION**.

SYMBOL	DENOMINATION
	Dangerous voltage

	Crushing of the upper limbs
	Entanglement
	Dragging
	Prohibition of access by unauthorized persons
	Do not remove safety devices
	Do not clean, oil, grease, repair or adjust by hand parts in motion
	General danger
	Protective gloves required
	Safety footwear required
	Safety helmet required
	Disconnect from power source before starting work or repairs.

1 – GENERAL INFORMATION
1.1 – IDENTIFICATION DETAILS OF MANUFACTURER

MANUFACTURER	Powerel srl
FACTORY	Via Retrone 32/A, 36077 Altavilla Vicentina (VI), Italy
HEADQUARTERS	Via Retrone 32/A, 36077 Altavilla Vicentina (VI), Italy
TELEPHONES AFTER SALES AND SPARE PARTS	Tel.: 0039-0444-492397 Fax: 0039-0444-602193
CONTACTS	info@powerel.it - www.powerel.it

1.2 – IDENTIFICATION DATA AND NUMBER OF THE MACHINE

Each machine is identified by an  plaque on which are indelibly recorded the reference data of the machine. These data are also reported on the use and maintenance manual.
For any communication with the manufacturer or support centre always cite these references

1.3 – DECLARATIONS

Declarations are at the end of this manual.

1.4 – SAFETY REGULATIONS

All Powerel Machines were manufactured in accordance with safety regulations in force at the time of manufacture.

1.5 – INFORMATION ON TECHNICAL ASSISTANCE

The machine is under warranty, as provided for in the general conditions of sale. If during the period of validity there is malfunction or breakdown of parts of the machine which fall into the cases specified by the warranty, the manufacturer, after the necessary checks on the machine, will repair or replace the defective parts. It is reminded that any interventions made by the user, without the express written permission of the manufacturer, shall invalidate the warranty and release the manufacturer from any liability for damage caused by the defective product. This is particularly true when these changes are performed on safety devices, impairing their effectiveness. The same considerations apply when using non-original spare parts or other than those explicitly specified by the manufacturer as "SECURITY DEVICES. For all these reasons, we recommend that our customers always call our customer support team.

1.6 – PREPARATIONS BY THE CUSTOMER

Without prejudice to any other contractual agreements, it is the responsibility of the client:

- Preparation of the rooms, including any construction work and/or wiring required;
- Electrical powering of the machine, in accordance with the rules in force in the country of use

2 – DESCRIPTION OF THE RECTIFIER

2.1 – DESCRIPTION OF THE RECTIFIER

The current rectifier with switching technology products by Powerel provide current and voltage stabilized and adjustable with low ripple. Thanks to switching technology in high-frequency it is possible to control and regulate with reactivity of one order of higher than traditional SCR systems.

The internal reactance of suppression of the ripple ensures moreover comprehensive and inherent protection against accidental and permanent short circuits that can occur on the load during normal operation of the machine. Outputs are fully isolated from both the supply side and from the side signals allowing any type of connection between different Machines (anodes with cathodes etc.).

Thanks to the Powerel digital connection it is possible to connect the remote control panel even from a distance, with appropriate precautions it is possible to reach even hundreds of meters away. These features make Powerel current rectifiers extremely versatile and configurable according to the specific needs of each customer.

2.2 – FIELD OF USE

Current rectifiers are mainly used in the galvanic industry, for degreasing anodic and cathodic, for the electro-deposition, in particular the processes of purification and water treatment, for cataphoresis installations and for other less common applications but no less important or binding.

2.3 – CONSTRUCTIO CHARACTERISTICS MODULAR RECTIFIERS

Powerel has created an extremely flexible modular rectifier consisting of several independent modules that can be paralleled and configured between them.

The modules are constructed identical to each other, in the master-slave control configuration. With this solution, any module can be master or slave, if necessary, making plant shutdown almost unlikely due to a module that does not work. If it does happen the rectifier will continue to operate at reduced power while maintaining complete control of current and voltage up to make full use of the remaining power available.

In this configuration a "MASTER" module is identified, usually the first module closest to the instrument, and the other modules are configured "SLAVE".

For the replacement of a module or a card, see the MAINTENANCE chapter.

2.4 – CONSTRUCTIO CHARACTERISTICS MODULAR RECTIFIERS WITH POLARITY REVERSE

Powerel rectifiers can be made with a static inversion module that allows the supply of reverse currents and voltages. Depending on the currents involved, a compact or modular rectifier is provided.

More modules are paralleleable.

It is also possible to make rectifiers with partial inversions in processes where the reverse current is significantly lower than the nominal current, reducing dimensions and costs compared to the solutions of our competitors.

For maintenance see the relevant chapter.

2.5 – ELECTRICAL CHARACTERISTICS

Refer to the table at the end of the manual.

2.6 – CHARACTERISTICS OF CONTROL AND COMMUNICATIONS

Refer to the table at the end of the manual.

2.7 – DIMENSIONS AND WEIGHTS

Refer to the table at the end of the manual.

2.8 – ENVIROMENTAL CONDITIONS

The machine does not require special environmental conditions. Must be installed inside an industrial illuminated building which is ventilated and fitted with solid and level flooring.

Beware: the machine is not suitable for operation in environments with explosive atmospheres, or highly corrosive or have excessive dust.

Is forbidden use the machine in environments that are:

- in highly corrosive environments,
- present a fire risk,
- in an explosive atmosphere.

2.9 – LIGHTING

Lighting of the premises where the machine is installed must comply with the laws of the country in which it is installed and must in any case ensure good visibility at any point, must not create dangerous reflections and allow clear reading of the control panels and detection of the emergency buttons.

Since the machine has no independent sources of light, it is necessary that the working environment is provided with general lighting to ensure suitable lighting on each point of the machine.

2.10 – VIBRATIONS

In conditions of use, it should conform to the indications for proper use; the vibrations should not be expected to rise to dangerous levels

2.11 – NOISE EMISSION

The level of equivalent continuous acoustic pressure A-weighted workstations should not exceed 70 dB (A); the maximum level of instantaneous sound pressure of C-weighted jobs should not exceed 63 Pa (130 dB compared to 20 PAH IPa.

For other phonometric reliefs in the workplace, operations should be conducted in accordance with the standards prevailing in the country of use

2.12 – STANDARD SUPPLY

The machine is supplied complete for start in service. A kit is provided with:

- Instructions for use and maintenance (this manual);
- Plaque affixed with appropriate CE marking;

3 – SAFETY

3.1 – GENERAL SAFETY ADVICE



Before the switch on of the rectifier read the contained instructions in the manual and to attentively follow the indications in it you bring.

The manufacturer has made every possible effort in designing this machine to ensure it is as **INTRINSICALLY SAFE** as possible. It is also equipped with all the protection and safety devices deemed necessary and, finally, is accompanied by sufficient information to ensure the machine is used safely and properly. To this end, when necessary, the following information has been shown in each chapter for each man-machine operation:

- Minimum qualification of the operator required,
- Number of operators needed,
- State of the machine,
- Residual hazards,
- Means of personal protection necessary or recommended,
- Prevention of human error,
- Prohibitions/obligations relating to improper behaviours reasonable preventable.



These information must meticulously be respected

The user can usefully complement the information provided by the manufacturer with supplementary instructions supplied at work, obviously not in conflict with those presented in this handbook of instructions, to contribute to the safe use of the machine.

The machine is supplied with a suitable carpentry, the degree of protection is indicated in the tables at the end of this manual. There are no moving parts, except for the fans protected by special grids.

The operator still has to wear all the protective equipment as dictated by regulations (DPI) to avoid any crushing during movement and placement.

When necessary, further recommendations will be specified in the manual for the user relating to prevention measures, means of personal protection, information on how to prevent human error and to prohibition relating to reasonably preventable unauthorised actions.

It is still essential to follow carefully the following indications:

- It is absolutely forbidden to operate the machine without its protection, i.e. with the exterior frame disassembled.
- The washing operations must be carried out with electrical section separation devices and the throwing of water or direct contact with liquid is forbidden; only a damp sponge should be used, it is absolutely forbidden to intervene on the electronic components by any means except compressed air;
- Do not for any reason change the machine parts; in case of malfunction due to the failure to comply with the above, the manufacturer is not responsible for the consequences. It is advisable to request any modifications directly from the manufacturer;
- Clean machinery covering, panels and controls with soft, dry cloth or slightly dampened with a mild detergent solution; do not use any type of solvent such as alcohol or gasoline, as the surfaces could be damaged;
- Clean the covers of the machines, the panels and the controls with soft and dry cloths or slightly soaked in a mild detergent solution; do not use any type of solvent, such as alcohol or gasoline, as the surfaces may be damaged.

IMPORTANT!

The manufacturer is not responsible for damages caused by the rectifier to people, animals or things in case of:



- use of the rectifier by personal not adequately trained;
- improper use of the machine;
- defects of power supply, hydraulic or pneumatic;
- non correct installation;
- lacks of the maintenance required;
- changes or non authorized interventions;
- use of non original spare parts or not specific for the model;
- total or partial non-observance of the instructions;
- use contrary to rules national specifications;
- calamity and exceptional events.

General specifications.

For the proper functioning of the machine you need to have previously checked that all connections are fully closed, the machine is fully assembled and that the air filters (if expected) are cleans.

Checks and inspections.

Checks must be carried out by an expert; they must be visual and functional, with the aim of guaranteeing the safety of the machine. They include:

- Verification of all the safeties installed on the machine;
- Verification of all connections with pins and screws;
- Functional verification of the machine;
- Check the status of the machine.

The results of this review will be reported on a separate sheet.

**ATTENTION!**

If anomalies are noticed, these must be eliminate before putting again in operation the rectifier and the expert that it performs the verification must annotate on the card the reparatio giving so the approval to the use of the rectifier.

The person that performs the review, where dangerous anomalies are detected, must give timely notice to the manufacturer relating to the machine.

Putting the machine out of service where any malfunctions are detected leading to appropriate checks and/or repairs. Make sure that there are no objects among the parts of the machine.

In order to ensure maximum safety in the handling of the machine it is FORBIDDEN:

- to tamper with any part of the machine,
- to use the machine but not running at full efficiency,
- to modify the machine to change the use for which it was originally established without the explicit permission of the manufacturer or without assumption of full responsibility imposed by Italian Presidential Decree 459/96 (Machinery Directive);

3.2 – ENVISAGED USE



Machine operator level 1

CURRENT RECTIFIERS

The current rectifier is a electric machine capable of supplying direct current for the electrolysis process and therefore the supply side will be connected to electrolysis tanks by the user. It is fed with line voltage (usually 400 VAC).



The use of products / material different from those specified by the manufacturer, that they can create damages to the rectifier and situations of danger for the operator and / or the near people to the rectifier, are considered incorrect or improper.

3.3 – CONTRAINDICATIONS OF USE

The machine must not be used:

- For uses different from or not mentioned in this manual;
- In an explosive or highly corrosive atmosphere or where there is a high concentration of dust in the atmosphere;
- In environments where there is a risk of fire;
- Exposure to weather;
- In the absence of safety devices or where they are notworking;
- With electrical jumpers and/or mechanical means that exclude users/parts of the machine itself

3.4 – HAZARDOUS AREA



Electrical maintenance technician

In normal conditions of operation, the machine does not expose the user to hazardous parts.

POWER

Power is supplied with line voltage. The conductors are isolated and segregated in special containers or plugs/sockets.

SUPPLY

If the voltage supply of the machine exceeds the value established by legislation relating to low voltage, it will be necessary to segregate the machine in a place inaccessible to staff other than electrical maintenance staff otherwise it will be necessary to provide adequate insulation of the exit bars with a specific output cover.

FANS

Fans placed in front of the machine are separated by a grid that prevents access. During the operation of replacing and cleaning of filters (if expected), the machine must be switched off in advance and it must be ensured that the fans are stopped; following this the protective grid can be removed before proceeding to replace or clean the filters (if expected).

3.5 – SAFETY DEVICES

The machine is installed with the following safety devices:

- Circuit breaker,
- Segregated power supply box,
- Supply: see the specifications mentioned in section 3.4,
- Fans: removable grill with mechanical tool (screwdrivers)

3.6 – SIGNS

The signs to be installed near the machine and the working area of the same is are follows:

PRESENCE OF MACHINES IN TENSION



3.7 – RESIDUAL RISKS

DEFINITION OF RESIDUAL RISK:

"danger not entirely reducible through design and techniques of protection, that is, potential danger is not obvious."

It is necessary to emphasize the following residual risks that are present on the use of the machine and which cannot be removed.



WARNING: ELECTRICAL RISK FOR VOLTAGE PARTS

See the notes in the description of the electrical switchboard

4 – INSTALLATION

4.1 – TRANSPORTATION AND HANDLING



Lifting and handling workers

The machine can be transported employing normal means capable of withstanding the weight and dimensions of the same; being supplied entirely assembled, they need only be positioned in the place of use. If to be combined with other equipment, leave sufficient space for installation and any areas of operation for the movement. It is preferred to lift the machine using a forklift truck fitted with forks. In the case of rectifiers in cabinet, it is possible to move it by lifting it from the bottom with the use of a forklift truck (after removing the base covers), or from above using the 4 eyebolts designed for lifting.

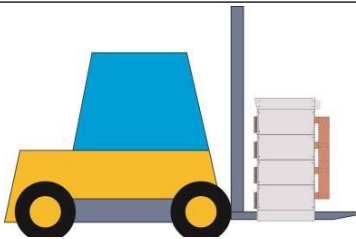
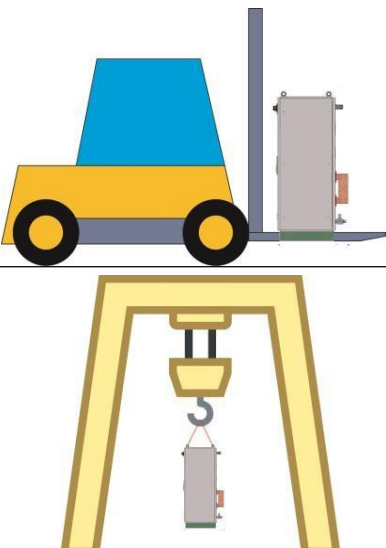
<p>TM</p>	
<p>TW</p>	



The manufacturer doesn't answer of the damages provoked to people or things for the use of different systems of lifting from those above described.

4.2 – STORAGE

If idle, the machine must be stored by taking the following precautions:

- Store the machine in an enclosed area;
- Grease the unpainted parts;
- Protect the machine from shock and stress;
- Protect the machine from moisture and high temperature ranges;
- Prevent the machine from coming into contact with corrosive substances;

4.3 – PREPARATIONS



Electrical maintenance technician

Installation preparations:

For installation, it is necessary to prepare an area of manoeuvre appropriate for the size of the machine and for the pre-determined means of lifting.

The preparation of the machine must be conducted in such a way as to ensure optimum ergonomics and safety of the workplace: leave around the same sufficient area to allow easy operation of use and handling of the material to be processed and for the operations and maintenance and adjustment.

Preparation of the electrical installation

The connection to the electrical system and combines synchronicity with the other machines must be conducted by qualified personnel observing the electrical schematic and the provisions prescribed by the law and/or technical regulations governing matters of security at places of work and existing electrical installations.

Adequate security for the operation of the machine should be organized as required in relation to safety in the workplace.



The company is not responsible of damages to things, people animal e/o caused by the not observance of such disposition.

To achieve an adequate level of safety, the electrical system which is part of the machine should provide, and as the full responsibility of the user, an earthed system in accordance with the provisions of the country of the user, and any other measures for the proper execution in accordance with best practice, according to those laws and/or technical regulations relating to matters of safety in the workplace and electrical installations.

Prepare connections for the ground of the machine housing.



ATTENTION!

Such predispositions it is always however in charge and under complete responsibility of the user and nothing can be imputed to the manufacturer for damages to things, people animal e/o for a bad electric connection.

4.4 – POSITIONING

The machine must always be placed on a perfectly flat level.

To allow maintenance and repair operations, each rectifier must be easily accessible and the following areas of respect must be left:

Modular rectifiers air cooled

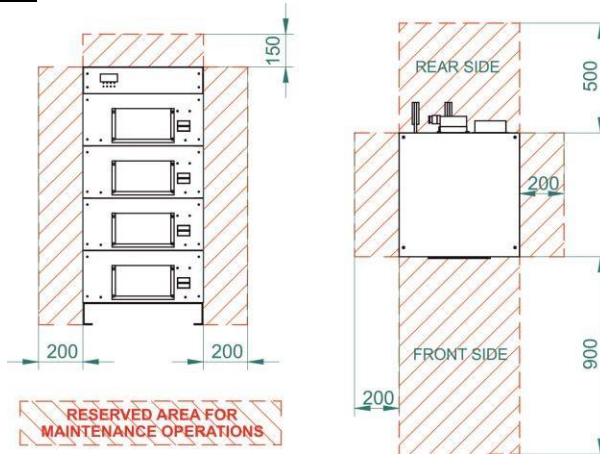

Compact rectifiers

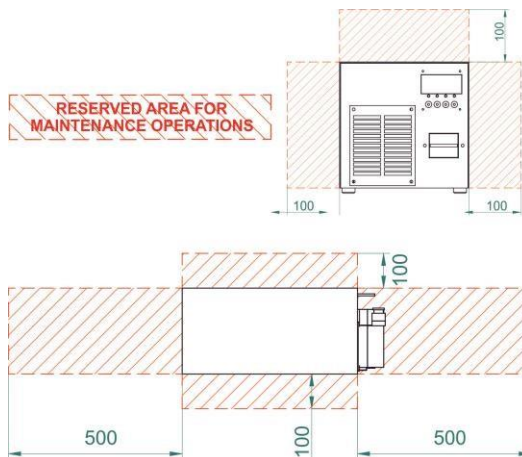

Modular rectifiers water cooled

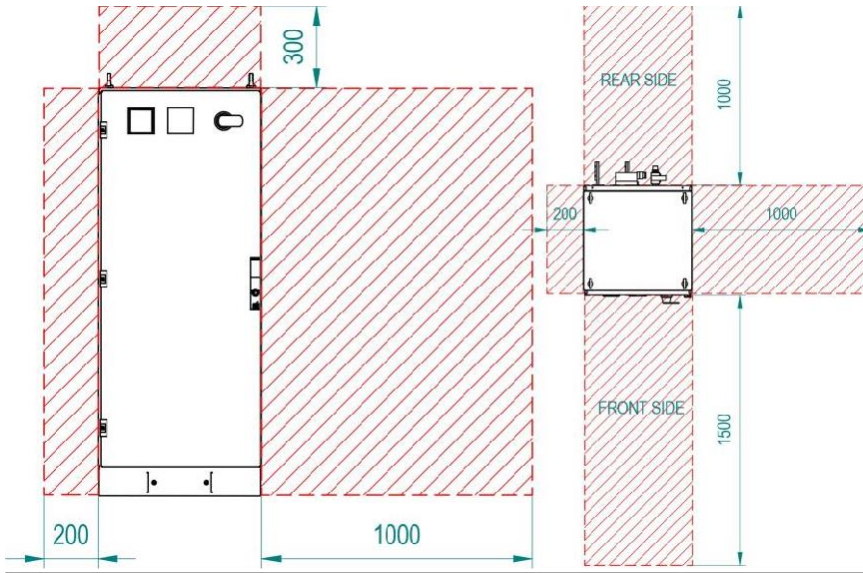

4.5 – PREPARATIONS



Electrical maintenance technician

Electrical connections

The electrical connection between the machine and the power supply line of the electric distribution of the customer shall be performed by qualified personnel supplied by the Client.

4.6 –MULTI-TOWER RECTIFIERS – CONNECTIONS

PASS BUS CONNCTIONS

If the rectifier is composed by many towers, it need to connect by ETHERNET cable included in the supply.

ELETRICAL CONNECTIONS

The eletrical connections (power supply) must be done for eact sigly tower

OUTPUT CONNECTION

In fuctions of rectifier configuracions (series o parallel), the tower must be connect as the following picture;

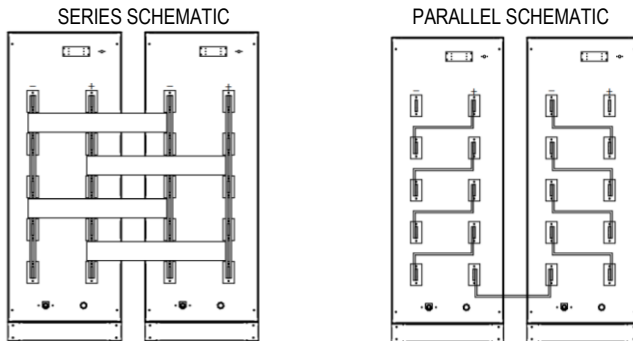

It is not possible change the the standard configuracion (series o parallel) of rectifiers.

4.7 – PRELIMINARY CHECS



Machine operator level 1

Prior to any formal functioning of the machine, it is necessary to carry out the following operations:

- Checking of all safety systems,
- Protection checks,
- Signalling checks.

Before the operation of the machine it is necessary to perform a series of checks and tests to prevent errors or accidents during the setting up stage to:

- Check that the machine has not been damaged during assembly;
- Check with special attention, the integrity of switchboards, control panels, electrical cables and tubes;
- Check the correct connection of all external sources of energy ;

4.8 – NO LOAD TESTS



machine operator level 2

Having established that the diagnostic control panel does not show anomalies, switch to manual control using the DE100 control panel, select the control voltage, set a voltage equal to about half the maximum value and then proceed to no load start (electrical load of disconnected use). Check the reading on the panel; check also, with an external voltmeter, that the continued voltage output is that being read by the control panel. Check the correct response to the commands during operation and stop.

4.9 – LOAD TESTS



machine operator level 2

Having established that the diagnostic control panel does not show abnormalities, switch to manual control using the DE100 control panel, select the current control, set a current equal to about half the maximum value and proceed to load start (electrical load permanently connected to the user). Check the reading on the panel, also verify through an external ammeter (if possible) that the continued current output is that being read by the control panel. Check the correct response to the commands during operation and stop.

5 – USE OF MACHINE

5.1 – ELECTRICAL CONNECTIONS, INSTRUMENTATION AND SIGNALS



Electrical maintenance technician

For the electric connections and accessories please refer to the end of the manual.

5.2 – MACHINE SETTINGS

Using the instrumentation on the machine (or remote), is possible to set all the machine functions.
For operator and process safety, we recommend you reserve setting operations of the machine for qualified staff:



Machine operator level 1

while the functioning settings also for:



Machine operator level 2

5.3 - RUNNING AND STOPPAGE

Monostable control



Press key to switch the rectifier on or off.

Maintained action command (Activated by the manufacturer)



Keep pushed the key to switch on the rectifier on release for switch off.



The status is displayed by the leds **ON** or **OFF**



5.4 - VOLTMETER AND AMMETER

It is the default display of the rectifier and indicates the voltage and current instantaneously supplied. From any point of the menu, you can



return to default pressing key .

In every status of the rectifier, you can modify the



voltage or current values using keys . Based on the stabilisation chosen being voltage or current, the respective values will be modified.

VOLTMETER AND AMMETER



SET VOLTAGE



SET CURRENT





5.5 - POLARITY REVERSAL (ONLY FOR MACHINES THAT PROVIDE IT)

Polarity reversal enables the rectifier to deliver the desired voltage either directly or inversely to the output bars.

Switching output voltages

Press the key  until the menu **rEU** (reverse) is displayed

With   buttons it is possible to choose between reverse voltage supply operation (**rEU On**) or direct voltage (**rEU OFF**).

Switching between direct and reverse is not possible with the rectifier running.

REVERSE VOLTAGE



DIRECT VOLTAGE



Voltage/current display

On the initial page of the instrument, in case of reverse voltage operation selection, **Ur** and **Ir** will be displayed, and in voltage and direct operation, **U** and **I** will be displayed.



DIRECT VOLTAGE DISPLAY



REVERSE VOLTAGE DISPLAY



5.6 - STABILISATION SELECTION



Press the key  until the stabilization menu is displayed, with keys   is possible the choice between current and voltage. If the machine is stabilised in

current mode, the led  is on.

Functioning variation is also possible while the rectifier is running.



5.7 – TIMER

Press key  until the timer menu is displayed and use keys  set the time after which the rectifier will stop. Set the time to zero for continuous functioning. When running, the time values set and residual to stoppage of the rectifier will be displayed. If the rectifier stops, for any reason, the timer is also reset and will restart from the set time value. Residual maintenance after stop: It is possible to set the rectifier so that, after the stop, the timer will not be resettled and therefore, at a subsequent restart, it will restart from the residual value reached. (Activated by the manufacturer) Restart after switch-off (black out): in cases of switching off and subsequent switch-on again the rectifier is normally in stop status. It's possible, however, set the rectifier so that when restarted, it is in the state prior to shutdown. To enable these two functions contact the technical service in the company. (Activated by the manufacturer) stoppage of the rectifier will be displayed.



5.8 – PROCESS TIME

Press the key  until the process time menu appears, the process time refers to the elapsed time since the last start command received and is reset to zero at the next new start command.



5.9 - RAMP



Press the key  until the ramp menu is displayed. The lower display shows the time set for the ramp function and can be changed using



 keys. The change is possible only in the stop state, at the next startup of the rectifier the ramping will be performed starting from the zero reference value until it reaches the set value.





5.10 - PULSED MODE FUNCTION (ONLY FOR MACHINES THAT PROVIDE IT)

In the "Pulsed Mode" configuration it is possible to repeat a square waveform for a certain period of time; the parameters that can be set are the current or voltage value (**SEt I** or **SEt U**), the total duration of the normal operating period (**PER t1**) in milliseconds, the total duration of the pulse period (**PER t2**) and the value of the pulse voltage or current (**REF t2**).

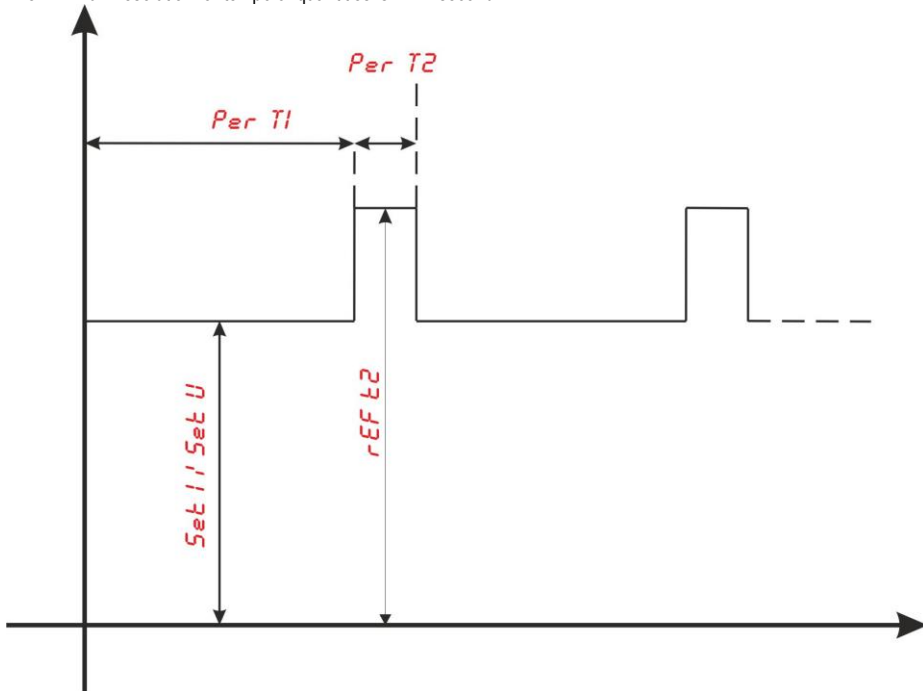
The minimum resolution for temporal quantities is 1 millisecond.



<p><u>Normal / pulsed operation</u></p> <p>Press the key  until the Pul menu is displayed.</p> <p>With the keys  it is possible to choose between operation with pulsed supply (Pul On) or traditional supply (Pul OFF). If pulsed supply is chosen, the menus described below will be enabled.</p>	<p>PULSED</p> 	<p>NOT PULSED</p> 
<p><u>Set period t1</u></p> <p>Press the key  until the upper display is shown.</p> <p>PER t1 and lower NS. With the keys  is possible to set the supply time in milliseconds.</p> <p>Press  to set the t2 period.</p>		
<p><u>Set period t2</u></p> <p>Press the key  until the upper display is shown.</p> <p>PER t2 and lower NS. With the keys  is possible to set the supply time in milliseconds.</p> <p>Press  to set the voltage or current pulse rEF</p>		
<p><u>Setting voltage or pulse current</u></p> <p>Press the key  until the upper rEF display appears and lower U (if in voltage control) or I (if in current control). With the keys  it is possible to set the desired pulse value.</p>		

5.11 - TEMPERATURE MODULES



Press the key  until the temperature display menu for each rectifier module is displayed.

The first display shows the module number (Nr 01 the first module starting from the top), and the second display shows the detected temperature. In rectifiers with more



than one module, using the keys  it is possible to change modules from which to read the relevant temperature.

This data allows you to estimate the thermal margin still available before the machine stops due to overtemperature. Unless otherwise stated, the set limits are as follows: Cooling fan start 45°C, Fan stop 35°C, Thermal alarm 75°C.



5.12 – CURRENTS DELIVERED MODULES



Press the key  to the menu displaying the current output of each rectifier module. The first display shows the module number (Nr 01 the first module starting from the top) and the second display shows the current delivered. In rectifiers with more than one



module, using the keys  it is possible to switch modules from which to read the relevant current delivered.





5.13 - PARTIAL AND TOTAL AMPERE MINUTES

Press the key  until the manu **AN PAR** is displayed, the partial ampere minutes and with a subsequent pressure the totals will be displayed. The standard configuration includes the set in Ampere Minutes. By changing the display scale from the "AMPERE MINUTE METER SCALE" menu it is possible to display in Ampere Seconds or Ampere Hour.



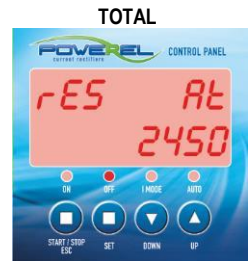

5.14 - PARTIAL AND TOTAL AMPERE MINUTES RESET

Press key  until the reset menu of the partial counter is displayed. Simultaneously press keys  for 2 seconds to reset the partial counter. Then, pressing key  once, you access the total meter reset menu, with the same method you can proceed to reset the relevant meter.











5.15 - DOSER PUMPS (ONLY FOR MACHINES THAT PROVIDE IT)



Pump enabling
The device provides the management of 3 doser pumps (not included). The eventual activation must be carried out by the factory and requires a hardware endowment.

Press the key  until the menu for enabling the first dosing pump is displayed. In the upper display appears **PdoS** with by the reference number of the pump, in the lower one the status appears. Use the keys  to select the status: 0 = Not enabled, 1 = Enabled.
If you press further, if the selected pump is enabled, you go to the detail of the relevant pump, otherwise you pass to the next pump.





<p><u>Set Ampere Minutes dosing</u> Depending on the selected scale (Amp. Seconds or Amp. Minutes or Amp. Hour), the upper display shows AS, An, Ah, respectively, accompanied by the number of the relative pump, on the lower one the number of amps set in the relative scale appears. temporal choice.</p>  <p>Using the keys  further, with the rectifier stopped, it is possible to select the number of amps after which the pump will be activated. These instructions are valid for all pumps.</p>	
<p><u>Dosing time setting</u> After selecting the amps, the message tdoS appears in the upper display, accompanied by the number of the relative pump, the time in minutes and seconds of pump operation appears in the lower display.</p>  <p>Using the keys  further, with the rectifier in stop mode, it is possible to modify this time. These instructions are valid for all pumps.</p>	
<p><u>Display of residual amps</u></p>  <p>With the rectifier on, press the button  until the word rES appears on the upper display, with the number of the relative pump, on the lower one the number of residual amps appears when the pump is activated in the relative scale selected. These instructions are valid for all pumps.</p>	

5.16 – ADDRESS

<p>Press key  until the address setting menu is displayed. Using the keys , in local control (led AUTO off) and in stop, enter the desired address, the display will always indicate the address already saved on the rectifier.</p>	
--	--

5.17 - FULL SCALE DISPLAY

Press key  until the full scale menu is displayed, the value is displayed in the bottom display.

Pressing the key again  the voltage full scale menu is displayed and in the bottom display, the relevant value. The full scale values are read by the rectifier and cannot be changed.



5.18 - LOCAL/AUTO FUNCTIONING SET (IF DISPLAYED)

Press key  until the control menu is displayed.

Using the keys  to switch between local control (by the DE100 device) or automatic (usually requested of process control systems used, PLC type).

In the event of *Auto* functioning, the instrumentation only displays the information sent from the rectifier, but it is not possible to enter commands until the *LoCAL* control is restored. If automatic control is selected, the led is lighting.



5.19 - RECTIFIER SERIAL NUMBER

Press key  until the serial number menu is displayed. The serial no. of the rectifier is displayed, this number must always be read and communicated to the assistance center for handling the case. If the rectifier is without power supply, the serial number can be read from the machine label on the right side of the carpentry.



5.20 - WATER SOLENOID VALVE CONTROL / WATER RECTIFIERS

(ONLY FOR LIQUID MACHINES)

Allows to set the opening and closing temperatures of the general water solenoid valve to avoid the formation of condensation and also to manage the opening for system testing.

Water Test

Press the key  until the menu test solenoid valve is displayed.

With the keys  is possible to set a time (in hours) during which the water delivery solenoid valve remains forcibly open, after which it returns to the setting position. It is normally used during the testing operation of the installation.



Water delivery closure setting

Press the key  until the menu solenoid valve closing is displayed.

With the keys  is possible to set the temperature, in the range 20 ÷ 40 C °, below which the water delivery solenoid valve remains closed.



Water delivery opening setting

Press the key  until the menu solenoid valve opening is displayed.

With the keys  is possible to set the temperature, in the range 41 ÷ 50 C °, above which the water delivery solenoid valve remains open.



5.21 - LOW LEVEL VOLTAGE / CURRENT ALARM (IF ACTIVATED)

Minimum voltage or current threshold referred to the chosen stabilization. (Function activatable by the manufacturer).

Press the key  until the **LO-100** menu is displayed.

With the keys  it is possible set the percentage threshold referred to the value of current or voltage below which will sent an alarm signal.





Press the key  until the **TIME** (Timer) menu is displayed.

With the keys  it is possible set a time after the start of rectifier, under this the alarm of minimum voltage/current is not operating.



5.22 – PASSWORD ENTER EXTRA FUCTIONS

Using the key  to enter the password for log into extra fuctions.

Press the key  to enter in the respective functions listed in the chapter

If the passowrd is wrong ,will be send back to screen “ VOLTMETER AND AMMETER”



5.23 – EXTRA FUNCTIONS

Using the key  to set ON \ OFF functions .

Press the key  to enter the next functions.

AMPERE MINUTE METER SCALE

This function allows you to choose the ampere meter to display.

The default value is ampere-minutes **An**, with keys  you can choose between ampere-seconds **AS** and ampere-hour **Ah**.





The functions disable the function AUTO/LOCAL into work's menu (SEE PARAGRAPH 5.18).



The functions view the menu DOSER PUMPS (SEE PARAGRAPH 5.15).

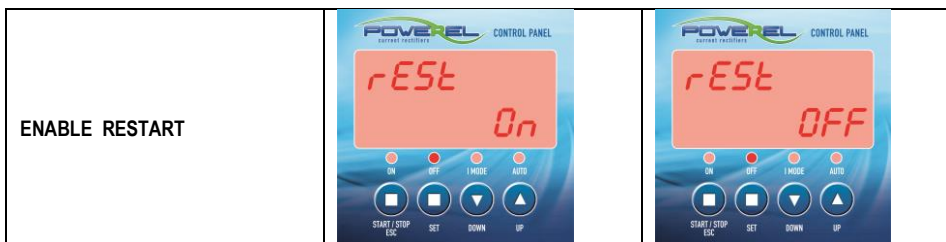

In cases of shutdown and subsequent restart, the rectifier is in the shutdown state. It is possible, however, to set the rectifier so that when it is turned back on it is in the state prior to being turned off (if off it stays off, if on it restarts but without ramping).











The functions active a contact when, in timer mode, the work's time setted is over.







<p>END OF CYCLE MODE</p>		
<p>Allows the connection of an alarm or other device that signals the end of the rectifier work cycle and the type of operation can be chosen between: Auto On: at the end of the cycle the contact is activated (e.g. alarm) and remains active for a settable time Auto Off: at the end of the cycle the contact is activated (e.g. alarm) and remains active until silenced by the operator</p>		
<p>ENABLE END OF CYCLE TIME</p>		
<p>In case of end cycle mode On active, with this function it is possible to set the time of notification signal.</p> <p>The default value is 0, with the keys  is possible to change the value.</p>		
<p>ENABLE DERATING</p>		
<p>It is a particular mode of operation where the rectifier, in proximity of extreme working conditions with temperatures close to the alarm threshold, automatically reduces the power supplied at intervals of 10% of the set value until the operating temperature stabilizes. If the conditions allow it, it is able to restore the original power.</p>		

<p>ENABLE MODBUS TCP \ RTU</p>		
<p>The function active MODBUS TCP \ RTU protocol. Note: this function is alternative exclusive to the PROFIBUS \ PROFINET.</p>		

<p>IP ADDRESS SETTING MASTER COMMUNICATION PORT (MODBUS TCP \ RTU PROTOCOL)</p>		
<p>With this function you can choose the IP address of the master communication port of the rectifier.</p> <p> Press the key to change the first of the four numbers. The default value is 192.168.1.207</p>		
<p>Use the keys and the key to change the four number groups.</p>		

<p>IP ADDRESS SETTING SLAVE COMMUNICATION PORT (PLC) (MODBUS TCP \ RTU PROTOCOL)</p>		
<p>With this function you can choose the IP address of the master communication port of the rectifier.</p> <p>Press the key  to change the first of the four numbers. The default value is 192.168.1.207</p>		
<p>Use the keys  and the key  to change the four number groups.</p>		
<p>ENABLE TEST485</p>		
<p>If active, the functions control the communication status, when the rectifier is running status, In case of lost connection, the rectifier stop.</p>		

<p>ENABLE PROFINET</p>		
<p>The function active protocol PROFIBUS \ PROFINET. Note: this function is alternative exclusive to the MODBUS TCP \ RTU.</p>		
<p>RESTART AFTER POWER FAILURE</p>		
<p>Residual hold after shutdown: It is possible to set the rectifier so that, after shutdown, the timer is not reset therefore, on a subsequent restart, it will restart from the residual value reached.</p>		
<p>ENABLE MINIMUM THRESHOLD</p>		
<p>The functions active the LOW LEVEL VOLTAGE / CURRENT ALARM menu (SEE PARAGRAPH 5.21)</p>		

<p>ENABLE START</p>		
<p>This function allow to change the  key behaviour. If Start is OFF you have to press the key  to toggle the status start/ stop, if Start is On you have to keep pressed the key  to remain in start mode.</p>		
<p>TYPE OF PROTOCOL</p>		
<p>The functions active the change of type of protocol. The default vaule is 1, with the keys  is possible to change the vaule.</p> <p>The type of protocol:</p> <ol style="list-style-type: none"> 1. Standard 2. Reserved 3. Hmi (DE202) PROTOCOL 4. Reserved 5. Standart pulde protocol 6. Percent pulse protocol 		



Limit of erogation referred to not controlled set of rectifier.

This function, if enabled, limits the output of the uncontrolled set to the value less of found scale of the machine. Use the unused set (voltage/current) in advance to adjust the value and then work with the other set.

Example: Setting a voltage value of 5 V in a machine with full scale of 10V, when working in current control the rectifier will also limit the voltage to no more than 5V in any case regardless of the current set required. Similar behavior if you set a current value and then work in voltage control.



Stop occurs if the imposed limit is reached.

This function, if enabled, limits the output of the uncontrolled set to the value imposed when the limit is reached, like the previous case, the difference is that rectifier doesn't limit but switch in stop status. Use the unused control (voltage/current) in advance to set its value and then work with the control set.

Example: by setting a voltage set of 5 volts on a machine full scale of 10V, when working in current control the rectifier will in any case also limit the voltage to no more than 5V and stop when the limit is reached regardless of the current set required. Similar behavior if you set a current set and then work in voltage control.



Allows to set a new password to access extra functicons.

The default password is : 100



With the keys it is possible set the new password.

5.24 - ALARMS MANAGEMENT

The rectifier manages the following alarms for each module:

- Heat sink overtemperature
- Transformer overtemperature
- Board overtemperature
- IGBT alarm

Please refer to the MAINTENANCE chapter for alarm solutions.

Heat sink overtemperature:

The appears in the upper display and the indication **Air** o **H2O** (heat sink) appears in the lower display indication **to HOt** (temperature alarm), see figure on the right "ALARM TYPE". In rectifiers with more than one module, using the key



is possible to view which module the alarm is referring to, see figure on the right "MODULE".

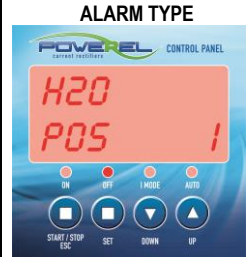

Transformer overtemperature:

The indication **trASFo** (transformer) appears in the upper display and the indication **to HOt** (temperature alarm) appears in the lower display, see figure on the right "ALARM TYPE". In rectifiers



with more than one module, using the key is possible to view which module the alarm is referring to, see figure on the right "MODULE".



Board overtemperature:

The indication **boArD** (card) appears in the upper display and the indication **to HOt** (temperature alarm) appears in the lower display, see the figure on the right "ALARM TYPE". In rectifiers with more than one module, using the



key **SET** is possible to view which module the alarm is referring to, see figure on the right "MODULE".

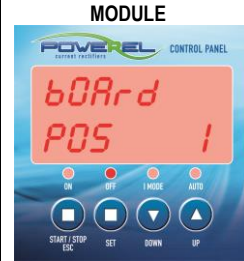

IGBT alarm:

The indication **AL-PO** (power alarm) appears in the upper display and the indication of the module to which the alarm is referred to appears in the lower display, see figure on the right "ALARM".

IGBT ALARM



6 - MAINTENANCE

6.1 – SPECIAL PREACUTIONS



Electrical maintenance technician

During maintenance or repair, it is good practice to apply the following advice:

- Before starting work it is necessary to expose a "SYSTEM IN MAINTENANCE" sign in a clearly visible position and proceed to isolate the machine from the power supply ;
- Do not use solvents or flammable materials;
- To access the highest parts of the machine, use those means appropriate to the operation to be performed;
- Do not climb on the parts of the machine because they are not designed to support the weight of persons;
- At the end of the task, restore and fix properly all the protections and guards removed or open



The manufacturer will not responsible for the non-observance of the list recommendations and from every other different use or not mentioned in the present indications.

6.2 – MAINTENANCE



Electrical maintenance technician

The machine has been designed to minimize routine maintenance, it is up to the operator to judge the state of the plant and its suitability for use.

It is recommended to stop and intervene with maintenance whenever non-optimal operation is felt, this will always allow maximum efficiency.



The not respect with the requests, exonerates the manufacturer from any liability for the effects of the guarantee.

Maintenance operations must be carried out with the machine in the conditions described in the "PRECAUTIONS" section of this chapter:

MAINTENANCE	SCHEDULING	TP	TM	TW
Filter cleaning	<i>Every month or more depending on the environmental conditions</i>	✓	✓	
Filter replacement	Every 12 months or more depending on environmental conditions	✓	✓	
Replacement of cooling fans	After 20000 hours in heavy duty 24h 45 ° C	✓	✓	
Output bar tightening	Installation	✓	✓	✓
Polycarbonate cleaning	Every month in operation of environmental conditions	✓	✓	✓
Instrument replacement	Upon indication of the manufacturer	✓	✓	✓
Power board replacement	Upon indication of the manufacturer	✓	✓	✓
Power module replacement (modular rectifiers)	Upon indication of the manufacturer		✓	✓
Ground connection check	Every 2 years	✓	✓	✓
Visual inspection	Every month	✓	✓	✓

ATTENTION !



Before every operation of maintenance, the maintenance-man must exclude the power supply acting on the principal breaker circuit, to close the padlock in endowment of the electric box, and to hold the key in secretary environment

Cleaning and replacement of the rectifier's filters

Disconnect the machine from the mains and wait 5 minutes before proceeding.

Compact rectifiers: remove the front panel of the module object of the maintenance by unscrewing the 8 fixing screws, Extract and clean the filtering elements with compressed air, in any case do not blow air inside the machine.

If the filter is replaced, the one replaced must be disposed of in compliance with the laws in force.

Fan replacement

Disconnect the machine from the mains and wait 5 minutes before proceeding.

Remove the front panel of the module object of the maintenance by unscrewing the 8 fixing screws, replace the failed fans and close the machine.

Restore the power supply and carry out a verification test by starting up the machine on load and checking that the fan starts after the rectifier has reached the temperature of power on of fans (45 ° C).

The use of non-original fans does not guarantee the expected duration indicated in the "scheduled maintenance" table as well as not guaranteeing the full load performance of the machine.

Tightening of the exit bars

Make sure that the bolts of the exit bars are tightened and that the relative grower spring are present.

Otherwise, completely unscrew the bolts releasing the copper bars or the cable lugs, clean them using solvents or abrasive belt with very fine grain. Tighten the bars vigorously, making sure that the two surfaces are in perfect contact with each other.

Polycarbonate cleaning

Clean the instrument only externally using special solvent-free products.

Instrument replacement

If it is faulty and after having contacted the technical assistance beforehand, if it is necessary to replace the instrument, the following indications must be followed:

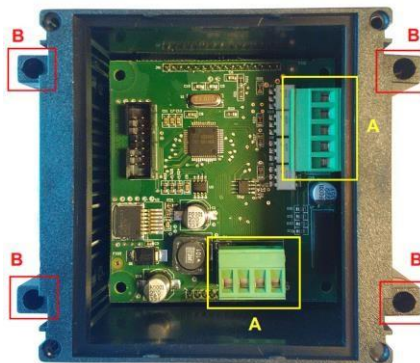

- Unplug the power of the rectifier,
- Open the lid of the rectifier by unscrewing the screws provided,
- Remove the plugs "A"
- Remove the "B" supports,
- Replace the instrument,
- Insert "B" supports and screw,
- Connect the plugs "A"
- Close the rectifier with the screws provided,

Power board replacement

The disassembly and replacement operations of the power board are assisted by a practical video on the main page of our site www.powerel.it.

Power plan module replacement (modular rectifiers)

The modular configuration designed by Powerel allows the electrical maintenance technician to independently replace any faulty module.

In case of failure, the instrument on board DE100 reports the module concerned.

The disassembling operation for replace the module are assisted by a practical video on the main page of our site www.powerel.it.

Grounding check

Check the continuity of the earth circuit by carrying out the continuity measurement according to the provisions of the CEI 44 - 5 III art. 19.

Visual inspection

Visually check the condition of the individual parts making up the machine, checking that there are no alterations due to sagging or deformation.

6.3 – ALARMS

Depending on the type of alarm displayed on the panel, the following actions are suggested:

Transformer overtemperature - Heatsink overtemperature - Board overtemperature

SOLUTIONS	REF.TO MAINTENANCE
1. Locate the module interested	
2. Check the cleanliness of the filters and replace them if necessary	Cleaning and replacement of the rectifiers filters
3. Check the operation of the fans and replace if necessary	Replacement fans
4. Check the temperature of the input air of the fans (Max. 40 ° C	External conditioning to reduce the temperature of the input air

IGBT Alarm

SOLUTIONS	REF.TO MAINTENANCE
1. Locate the module interested	Contact the assistance

7 – SPARE PARTS AND ACCESSORIES**7.1 – ASSISTANCE**

For any information in relation to the use, maintenance, installation, etc of the machine, the manufacturer is always at disposition. From the customer is needed to put the questions in clearly with reference to this manual.

7.2 – SPARE PARTS

For any spare part, contact the manufacturer.

ALWAYS USE ORIGINAL SPARE PARTS.



The constructor doesn't respond of break-ups, malfunction or damages to people or consequential things from the use of non original parts

The use of non-original spare parts is not recommended and where this happens, the terms of the Guarantee will not be valid (if still under Guarantee) as well as the manufacturer's Liability in the use of the machine/installation and any damage resulting to persons and/or property.

8 – FURTHER INSTRUCTION**8.1 – WASTE DISPOSAL**

The disposal of the particular replaced should be carried out according to the laws in force in the country where the machine is being used.

8.2 – PUTTING OUT OF ACTION AND DISMANTLING

When dismantling, it is necessary to separate the plastic and electrical components, which must be sent to different collection points in compliance with the legislation in force.

With regard to the metal mass of the machine, dividing between the steel and other metals or alloys is sufficient for the purposes of recycling.

8.3 – SAFE WORK PRACTICES

Instruct on the specific procedures and inform employees adequately for:

- Safe use of the machine,
- Emergency situation

9 – ANNEXED

9.1 - TP SERIES RECTIFIERS DIMENSIONS

P11



P10



P13



V I	6	8	10	12	16	20	Case Case	Dimensioni l, p, h Dimensions w, d, h	Peso Weight
50							P11	260 x 500 x 230 mm	17 kg
100									
200							P10	250 x 585 x 250 mm	34 kg
300									
400							P13	387 x 610 x 280 mm	38 kg
500									
600									

9.2 - TP SERIES ELECTRICAL FEATURES

Power supply	<i>Three phase 400 VAC without neutral</i>
Current supplied	Max 600 A
Voltage supplied	Max 400 V
Polarity reversal	Max 200 A (ove prevista) Max 200 A (where applicable)
Standard efficiency	85 %
Max efficiency	92%
Power adjustment range	2% ÷ 100%
Ripple	< 2% (<=1% a richiesta)
Network isolation	2500V AC 60"
Connection interface (optional on demand)	Profinet, Profibus, Modbus-TCP, RS485 Modbus-RTU, 0-10V, 0- 20mA, 4-20mA
Max ambient temperature	40° C
Max humidity	85%
Protezioni e mantenimento Protections and maintenance	<i>Short circuit, over temperature, electronic cards tropicalization, epoxy painting or metal parts zinc plating, air filters, electronic parts protection.</i>
Grado protezione Protection grade	IP41
Raffreddamento Cooling	<i>Forced air</i>
Integrated electronics	<i>All module electronics are grouped into a single card.</i>

In any case refer to the data on the plate of the rectifier.

9.3 - FULL VIEW OF TP SERIES

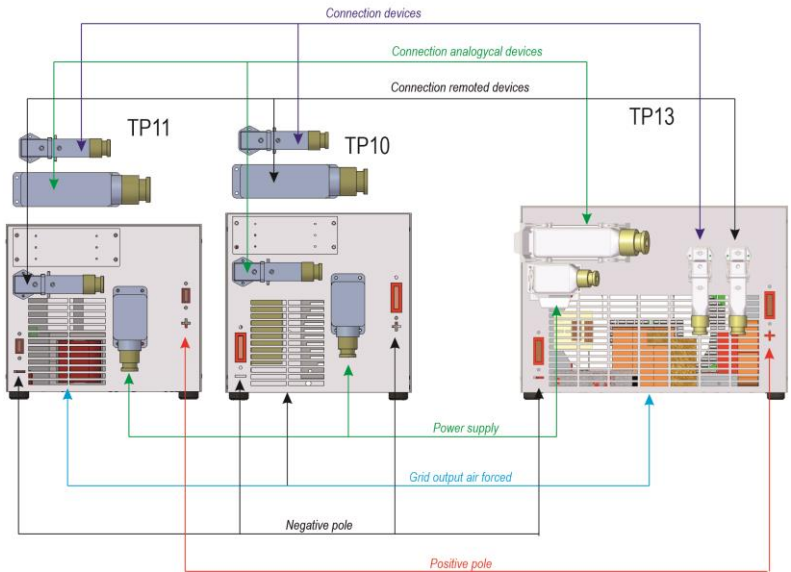
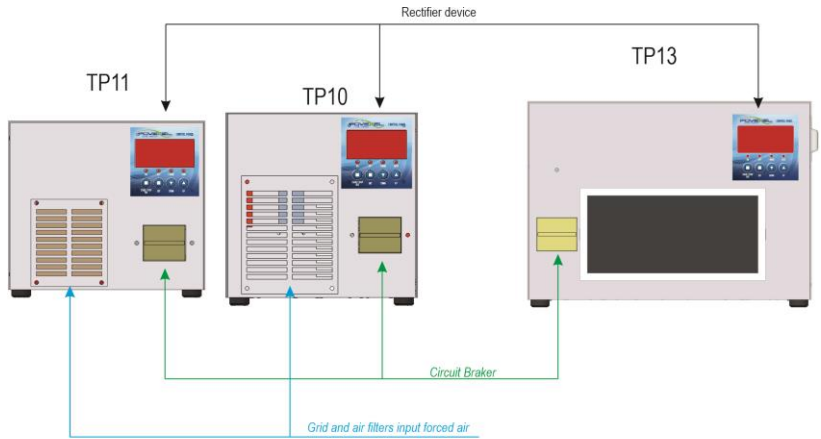

9.4 - POWER SUPPLY TP SERIES

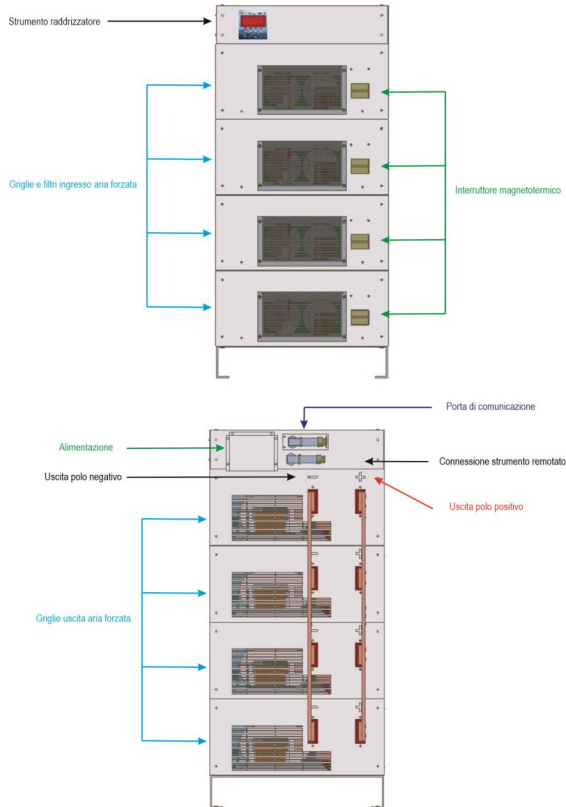

POWER SUPPLY	PHASE	DESCRIPTION	PLUG
THREE PHASE	L1	U PHASE	1
	L2	V PHASE	2
	L3	W PHASE	3
	GND	GROUND	5

9.5 - TM SERIES DIMENSIONS



MOD \ V	0-8	0-10	0-12	0-16	0-20	0-24	0-30	0-40	0-48	0-60	Dimensioni l, p, h Dimensions w, d, h	Peso Weight
T1	1000	1000	1000	1000	800	700	600	400	350	300	545 x 715 x 460 mm	84 kg
T2	2000	2000	2000	2000	1600	1400	1200	800	700	600	545 x 715 x 700 mm	138 kg
T3	3000	3000	3000	3000	2400	2100	1800	1200	1050	900	545 x 715 x 940 mm	192 kg
T4	4000	4000	4000	4000	3200	2800	2400	1600	1400	1200	545 x 715 x 1180 mm	246 kg
T5	5000	5000	5000	5000	4000	3500	3000	2000	1750	1500	545 x 715 x 1420 mm	300 kg
T6	6000	6000	6000	6000	4800	4200	3600	2400	2100	1800	545 x 715 x 1660 mm	354 kg
T7	7000	7000	7000	7000	5600	4900	4200	2800	2450	2100	545 x 715 x 1900 mm	408 kg
T8	8000	8000	8000	8000	6400	5600	4800	3200	2800	2400	545 x 715 x 2140 mm	462 kg
T9	9000	9000	9000	9000	7200	6300	5400	3600	3150	2700	545 x 715 x 2380 mm	516 kg
T10	10000	10000	10000	10000	8000	7000	6000	4000	3500	3000	545 x 715 x 2620 mm	570 kg

9.6 - TM SERIES ELECTRICAL FEATURES

Power supply rectifier	<i>Three phase 400 VAC without neutral</i>
Current supplied for each module	Max 1000 A
Voltage supplied for each module	Max 100 V
Module power	Max 16 kW
Max nr. controllable modules	32 - (parallel and series) <i>(direct and reverse currents)</i>
Tower modules	<i>Max 10, suggested 7 for transport problems</i>
Polarity reversal	<i>Max 1000 A per module (where applicable)</i>
Standard efficiency	85 %
Max efficiency	92%
Power adjustment range	2% ÷ 100%
Ripple	< 1%
Network isolation	2500V AC 60°
Connection interface (optional on demand)	<u>Ethernet</u> : Profinet, Modbus-TCP <u>Serial port</u> : Profibus, RS485 Modbus-RTU <u>Analogical</u> : 0-10V, 0-20mA, 4-20mA
Max ambient temperature	40° C
Max humidity	85%
Protections and maintenance	<i>Short circuit, over temperature, electronic cards tropicalization, epoxy painting or metal parts zinc plating, air filters, electronic parts protection.</i>
Protection grade	IP41
Raffreddamento - Cooling	<i>Forced air</i>
Flexibility and expandability	<i>It's always possible to add one or more modules to increase rectifier power.</i>
Integrated electronics	<i>All module electronics are grouped into a single card.</i>

In any case refer to the data on the plate of the rectifier

9.7 - FULL VIEW OF TM SERIES

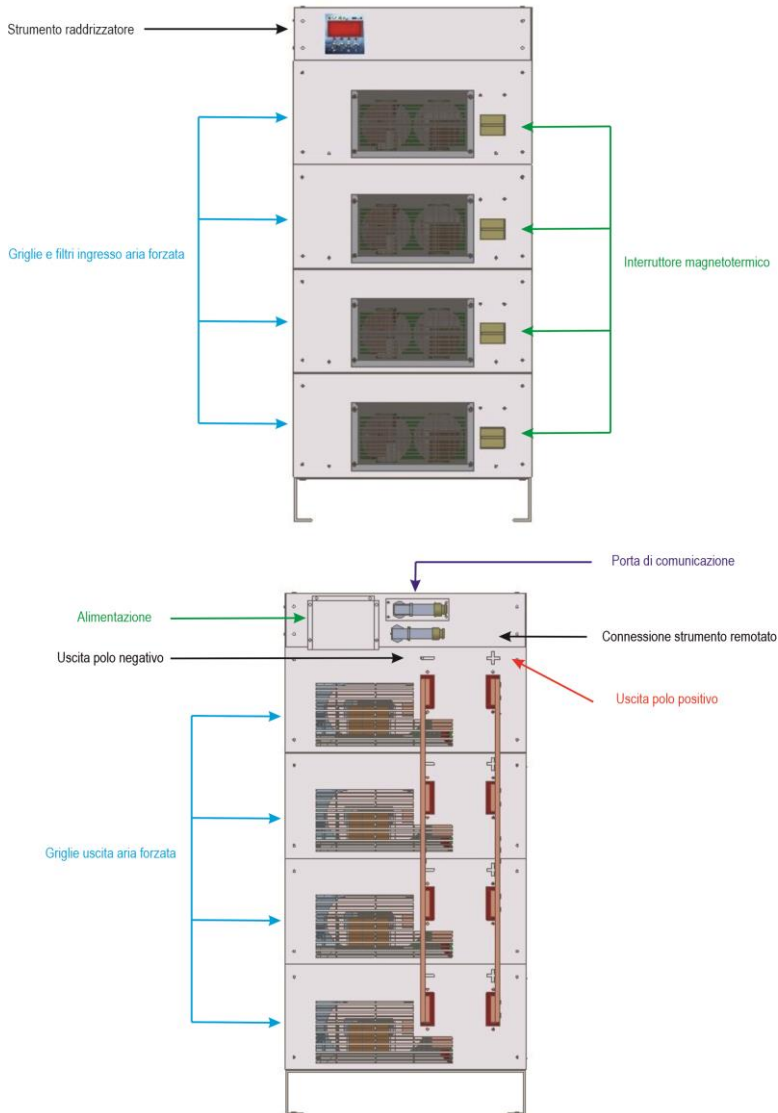

9.8 - POWER SUPPLY OF TM SERIES

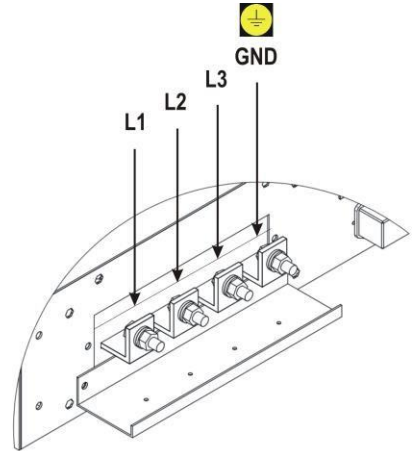
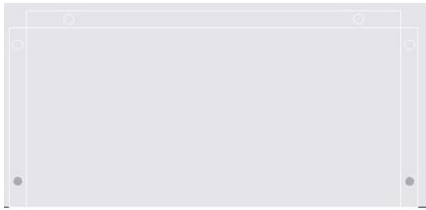

Get off the protection box and connect the cables following the drawn order

POWER SUPPLY	
L1	U PHASE
L2	V PHASE
L3	W PHASE
GND	GROUND

9.10- TY SERIES RECTIFIERS DIMENSIONS

P12



	V I	6	8	10	12	16	20	Case	Dimensioni l, p, h Dimensions w, d, h	Peso Weight
	500							P12	300 x 680 x 300 mm	38 kg

9.11 - TY SERIES ELECTRICAL FEATURES

Power supply	<i>Three phase 400 VAC + G 50/60 Hz</i>
Current supplied	Max 600 A
Voltage supplied	Max 400 V
Inversione di polarit� Polarity reversal	<i>Max 200 A (where applicable)</i>
Standard efficiency	85%
Max efficiency	92%
Power adjustment range	2% ÷ 100%
Ripple	< 2% (<=1% a richiesta)
Network isolation	2500V AC 60"
Connection interface (optional on demand)	Profinet, Profibus, Modbus-TCP, RS485 Modbus-RTU, 0-10V, 0- 20mA, 4-20mA
Max ambient temperature	50° C
Max humidity	90%
Protections and maintenance	<i>Short circuit, over temperature, electronic cards tropicalization, epoxy painting or metal parts zinc plating, air filters, electronic parts protection.</i>
Protection grade	IP43 (IP65 on demand)
Cooling	<i>Water</i>
Integrated electronics	<i>All module electronics are grouped into a single card.</i>

In any case refer to the data on the plate of the rectifier.

9.12 - FULL VIEW OF TY SERIES

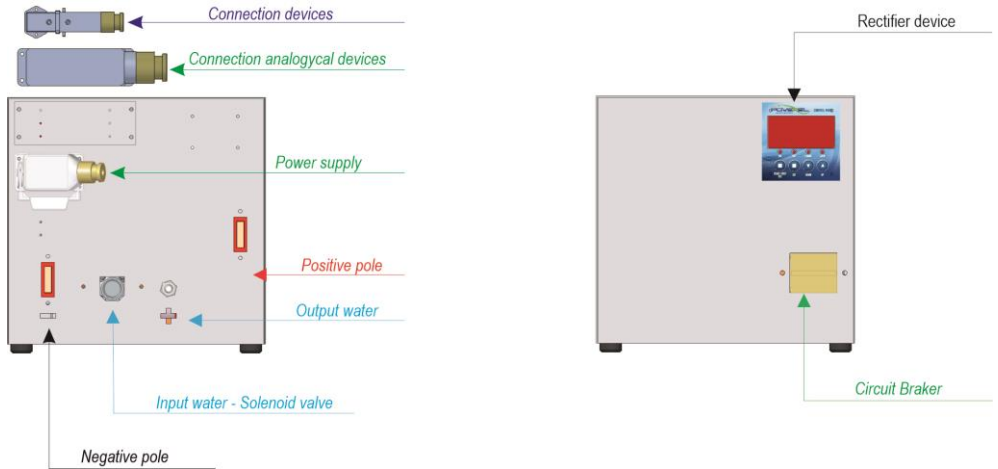

9.13 - POWER SUPPLY TY SERIES

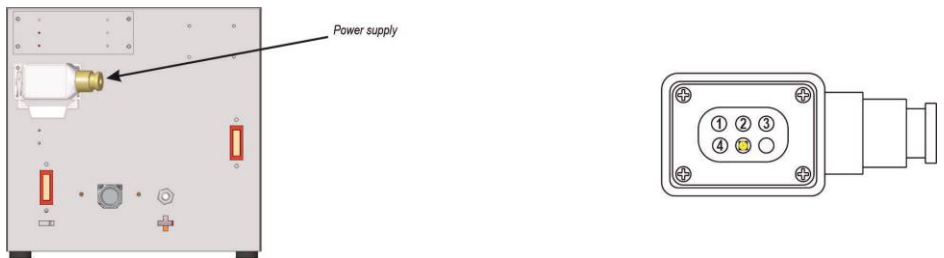

POWER SUPPLY	PHASE	DESCRIPTION	PLUG
THREE PHASE	L1	U PHASE	1
	L2	V PHASE	2
	L3	W PHASE	3
	GND	GROUND	5

9.14 - TW SERIES DIMENSIONS



MOD \ V	0-8	0-10	0-12	0-16	0-20	0-24	0-30	0-40	0-48	0-60	Dimensioni l, p, h Dimensions w, d, h	Peso Weight
W1	1250	1250	1250	1250	1000	800	700	500	400	350	600 x 730 x 750 mm	165 kg
W2	2500	2500	2500	2500	2000	1600	1400	1000	800	700	600 x 730 x 1000 mm	225 kg
W3	3750	3750	3750	3750	3000	2400	2100	1500	1200	1050	600 x 730 x 1250 mm	285 kg
W4	5000	5000	5000	5000	4000	3200	2800	2000	1600	1400	600 x 730 x 1500 mm	360 kg
W5	6250	6250	6250	6250	5000	4000	3500	2500	2000	1750	600 x 730 x 1750 mm	435 kg
W6	7500	7500	7500	7500	6000	4800	4200	3000	2400	2100	600 x 730 x 2000 mm	525 kg
W7	8750	8750	8750	8750	7000	5600	4900	3500	2800	2450	600 x 730 x 2250 mm	615 kg

9.15 - TW SERIES ELECTRICAL FEATURES	
Power supply rectifier	<i>Three phase 400 VAC without neutral</i>
Current supplied for each module	Max 1250 A
Voltage supplied for each module	Max 100 V
Module power	Max 20 kW
Max nr. controllable modules	32 (parallel and series) (direct and reverse currents)
Tower modules	Max 6
Polarity reversal	<i>Max 1000 A per module (where applicable)</i>
Standard efficiency	85 %
Max efficiency	92%
Power adjustment range	2% ÷ 100%
Ripple	< 2% (<1% a richiesta)
Network isolation	2500V AC 60"
Connection interface (optional ondemand)	Ethernet: Profinet, Modbus-TCP Serial port: Profibus, RS485 Modbus-RTU Analogical: 0-10V, 0-20mA, 4-20mA
Max ambient temperature	40° C
Max humidity	85%
Protections and maintenance	<i>Short circuit, over temperature, electronic cards tropicalization, epoxy painting or metal parts zinc plating, air filters, electronic parts protection.</i>
Protection grade	IP55
Raffreddamento	<i>Water</i>
Temperature range admitted during water supply	25-40 C°

Temperature difference during water way out	7 C°
Max pressure	6 BAR
Circuit conductivity	250 μ S/cm
PH Value	7 ÷ 8 PH
Hardness due to carbonate	<8 dH; < 1.44 mmol/l; < 14.24 °fH
Aggressive carbonic acid	0 mg/l
Content of ammonia	0 mg/l
Chloride	< 20 mg/l
Sulphate	> 50 mg/l
Nitrate	< 50 mg/l
Grain size	< 0,1 mm
Flexibility and expandability	<i>It's always possible to add one or more modules to increase rectifier power.</i>
Integrated electronics	<i>All module electronics are grouped into a single card.</i>

9.16 - FULL VIEW OF TW SERIES RECTIFIERS

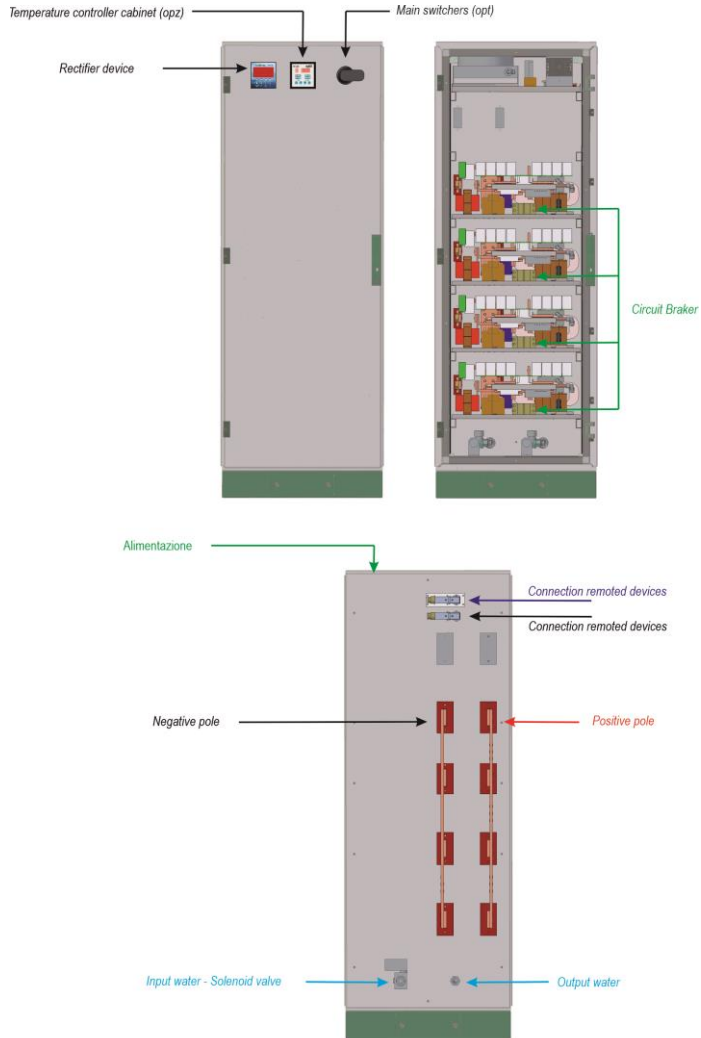

9.17 - POWER SUPPLY OF TW SERIES

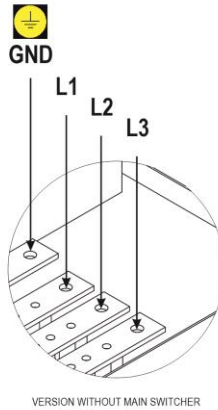
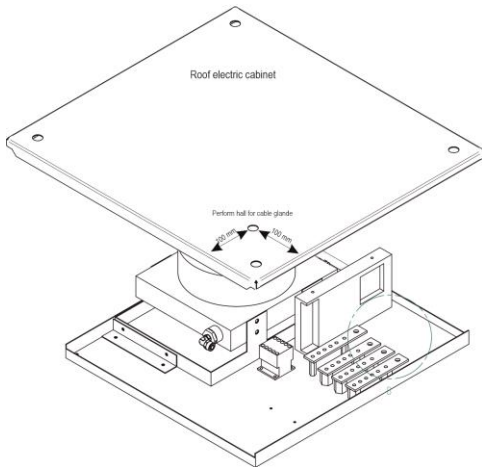
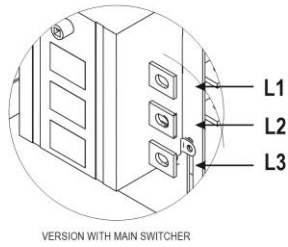
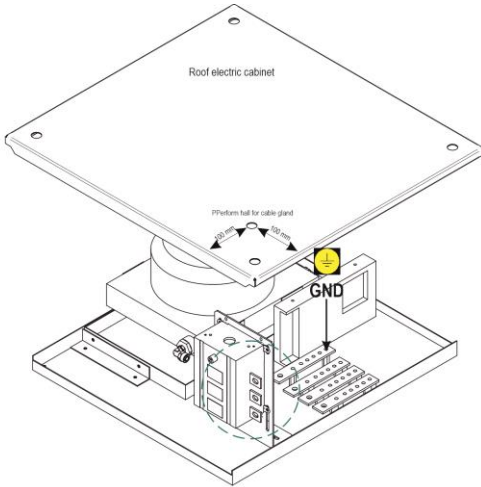

9.18 - DE100 REMOTED

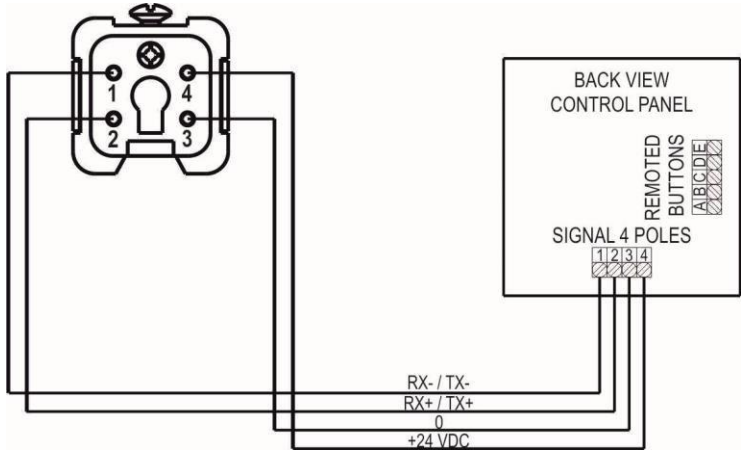

CONNECTIONS DE100 REMOTED		
RECTIFIER PLUG	CONTROL PANEL SIGNAL 4 POLES	SIGNAL
1	1	RX- / TX-
2	2	RX+ / TX+
3	3	0
4	4	+24 VDC

CONNECTIONS DE100 BUTTON REMOTED	
CORRESPONDANT BUTTON	CONTROL PANEL REMOTED BUTTONS
	A
	B
	C
	D
COMMON	E

9.19 - DE20X REMOTED

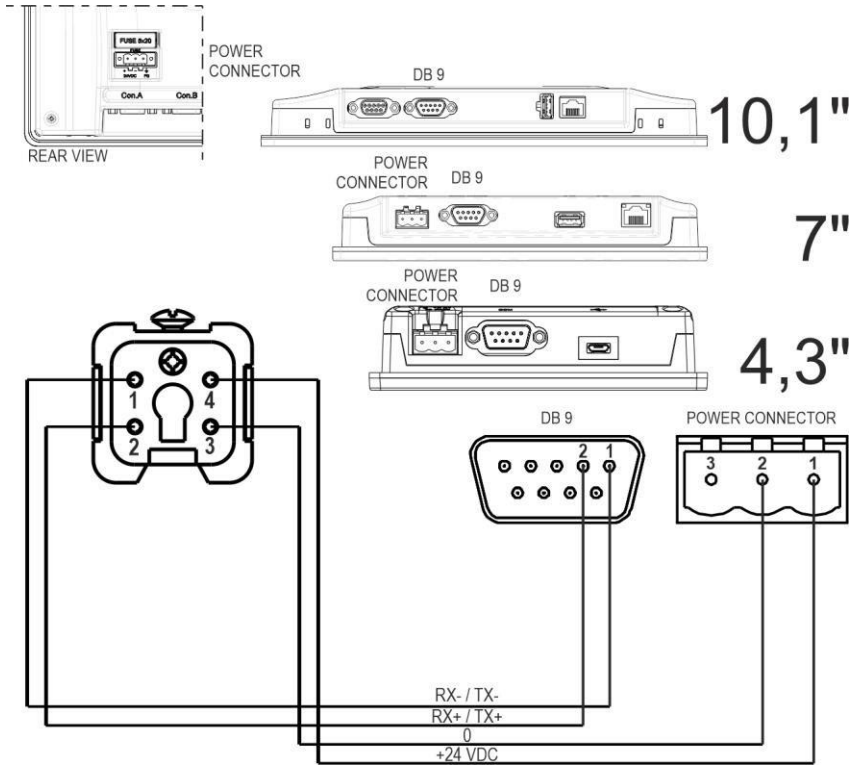

RECTIFIER PLUG	CONNECTIONS DE200 REMOTED		
	DB9	POW CON	SIGNAL
1	1		RX- / TX-
2	2		RX+ / TX+
3		2	0
4		1	+24 VDC

9.20 - DOSING PUMPS CONNECTION

Doser Pump plug 230 Vac

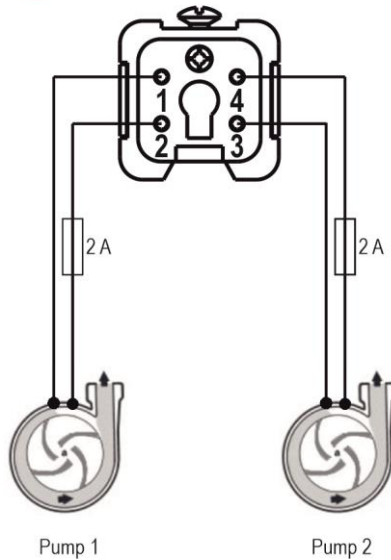
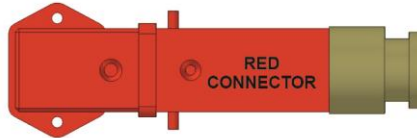

STANDARD 16 POLES CONNECTOR		
1	NEUTRAL	DOSING PUMP 1
2	PHASE	
3	NEUTRAL	DOSING PUMP 2
4	PHASE	
16		

9.21 - ANALOGICAL CONNECTION

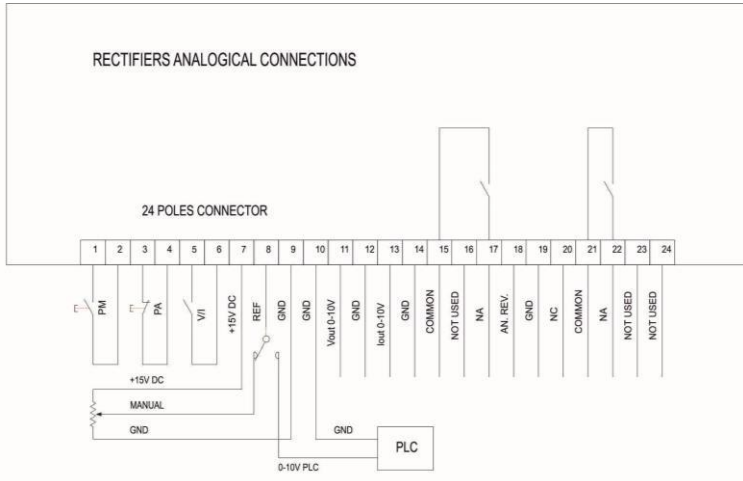

STANDARD 24 POLES CONNECTOR

1	RUN BUTTON (NORMALLY OPEN)
2	SIGNAL GROUND
3	STOP BUTTON (NORMALLY CLOSED)
4	SIGNAL GROUND
5	VOLTAGE/CURRENT SELECTOR (CLOSED FOR VOLTAGE CONTROL)
6	SIGNAL GROUND
7	+15 VOLT INTERNAL POWER SUPPLY (MAX 1 WATT)
8	INPUT SIGNAL SET 0-10 VOLT or 4-20mA
9	SIGNAL GROUND
10	SIGNAL GROUND
11	OUTPUT VOLTAGE 0-10 VOLT or 4-20mA for 0 V to FULL SCALE
12	SIGNAL GROUND
13	OUTPUT CURRENT 0-10 VOLT or 4-20mA for 0 A to FULL SCALE
14	SIGNAL GROUND
15	RUN RELAY (COMMON POLE)
16	NOT USED
17	RUN RELAY (NORMALLY OPEN POLE)
18	REVERSE MODE
19	GROUND
20	NOT USED
21	FAULT RELAY (COMMON POLE)
22	FAULT RELAY (NORMALLY OPEN POLE)
23	NOT USED
24	NOT USED

9.22 - MODBUS-RTU

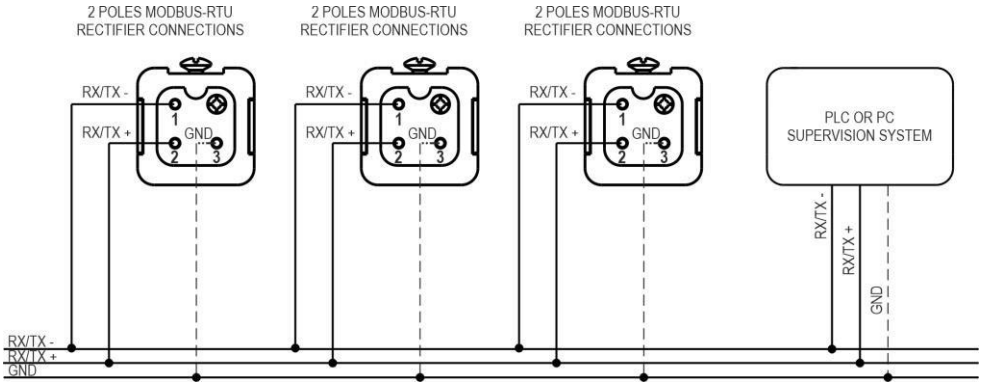

CONNECTION TABLE	
RECTIFIERS CONNECTION	PLC OR PC SUPERVISION SYSTEM
1	RX/TX -
2	RX/TX +
3	GROUND

9.23 - PROFIBUS-DP



CONNECTION TABLE

DB9:	STANDARD CONNECTION PROFIBUS
------	------------------------------

FOR REGISTRY TABLES CONTACT OUR TECHNICAL DPT	
---	--

9.24 – PROFINET – MODBUS-TCP



9.25 -- CONFORMITY DECLARATION CE

The manufacturer Powerel srl
Address Via Retrone 32/A, 36077 Altavilla Vicentina (VI), Italy

DECLARES THAT

The products identified on plate placed on the machine and on this manual:

AGREES TO THE DIRECTIVES

- **2014/35/EU EN 61204-7:2018 Low-voltage switch mode power supplies - Safety requirements**
- **2014/30/EU EN 61000-6-2:2005 Electromagnetic compatibility (EMC) - Immunity for industrial environments**
- **2014/30/EU EN 61000-6-4:2007 Electromagnetic compatibility (EMC) - Emission for industrial environments**

Altavilla Vicentina, 09 January 2023

Powerel srl
Technical Manager
Eng. Luca Gandolfi

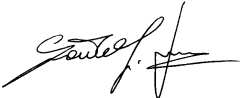



NOTES

A series of horizontal dashed lines spanning the width of the page, intended for handwritten notes.



NOTES

A series of horizontal dashed lines spanning the width of the page, intended for handwritten notes.



Powerel srl

Via Retrone 32/A - 36077 Altavilla Vicentina (Vicenza) - Italy
info@powerel.it - www.powerel.it

Rev. 202501